

PRISM® Loader



FEATURES

- Laser position for increased accuracy
- 10.4" color touch screen for machine controls
- Pneumatic gripper for loading and transporting
- Efficient German Nord® motor
- Flexible anti-collision safety bar

The PRISM Paper Loader is a high-volume, high-production machine built to streamline your cutting process. These heavy duty machines pick up and transport material to the front of the paper cutter. The ergonomic design allows cutting lines to transport sheets faster and more easily. It can be ordered for use on the right or left side of your paper cutter.



SPECIFICATIONS

Note: Sizes and specifications are for reference only and are subject to change.

Model	IPT-2	
Machine Depth (A)	92in	2350mm
Machine Width (B)	122in	3105mm
Back Stand (C)	22in	570mm
Min Sheet Size Length	25in	650mm
Min Sheet Size Width	19in	500mm
Max Sheet Size Length	50in	1280mm
Max Sheet Size Width	35in	900mm
Min Ream Height	1.5in	40mm
Max Ream Height	6.5in	165mm
Max Pile Height	51in	1300mm
Max Loading	551lbs	250kg
Unloading time	30-40sec	30-40sec
Power	200-240V, 50/60HZ	
Machine Weight	2204.62lbs / 1000kg	

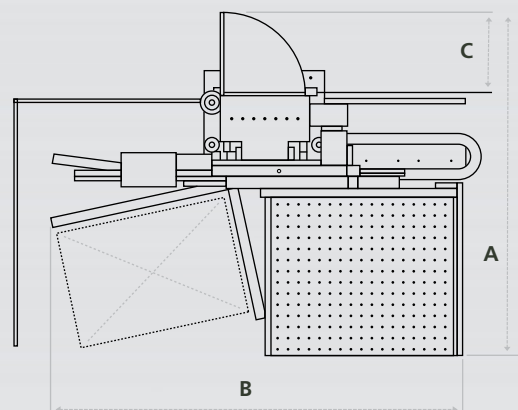

*This machine requires compressed air

For more information about this loader:
1.800.932.0780 or visit papercutters.com/loaders

PaperCutters.com
 POWERED BY COLTER PETERSON