

PRISM® Unloader

FEATURES

- Laser positioning for increased accuracy
- 10.4" color touch screen for machine control
- Low pressure air table with blower
- Efficient German Nord motor
- Flexible anti-collision safety bar

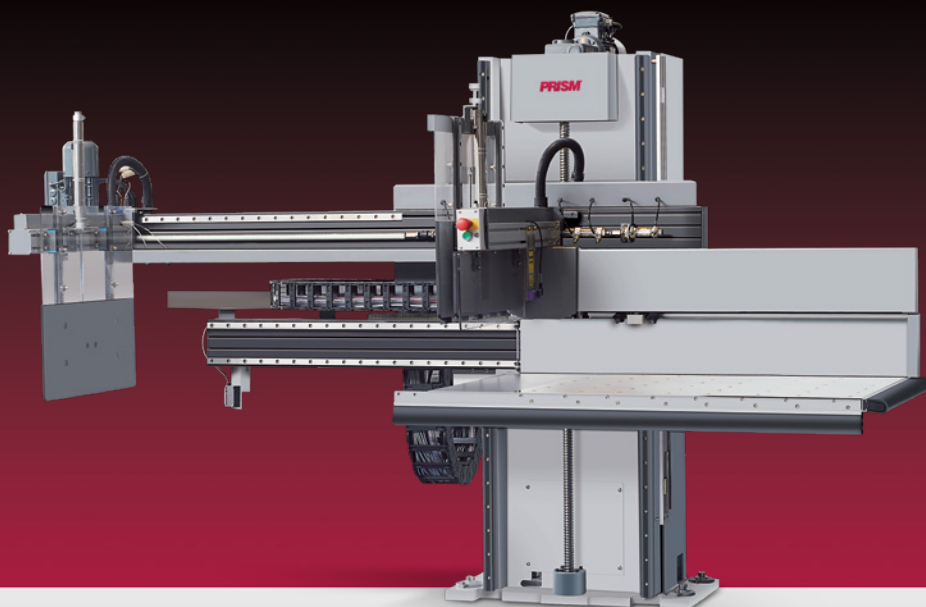

The PRISM Unloader is a heavy duty and cost effective addition to any cutting process. Its reliable, smooth operation--facilitated by a stainless steel transfer table with dual paddles that place piles of cut materials on the skid within seconds--normally increases cutting productivity by as much as 40%. They can be ordered to be used on the right or left side of your paper cutter.



**PARTS
WARRANTY**



**LABOR
WARRANTY**

SPECIFICATIONS

Note: Sizes and specifications are for reference only and are subject to change.

Model	LG-2		LG-4	
Machine Depth (A)	66in	1690mm	92 in	2350mm
Machine Width (B)	139in	3530mm	185in	4700mm
Min Sheet Size Length	15in	400mm	25in	650mm
Min Sheet Size Width	15in	400mm	17in	450mm
Max Sheet Size Length	49in	1260mm	64in	1640mm
Max Sheet Size Width	37in	950mm	48in	1220mm
Min Label Size	4.1in	105mm	4.1in	105mm
Min Label Size	5.8in	148mm	5.8in	148mm
Min Ream Height	1.5in	40mm	1.5in	40mm
Max Ream Height	6.5in	165mm	6.5in	165mm
Max Pile Height	51.2in	1300mm	63in	1600mm
Max Loading	441lbs	200kg	661lbs	300kg
Unloading time	18-30s		22-37s	
Power	200V-240V, 50/60HZ			
Machine Weight	2645lbs / 1200kg		4409lbs / 2000kg	

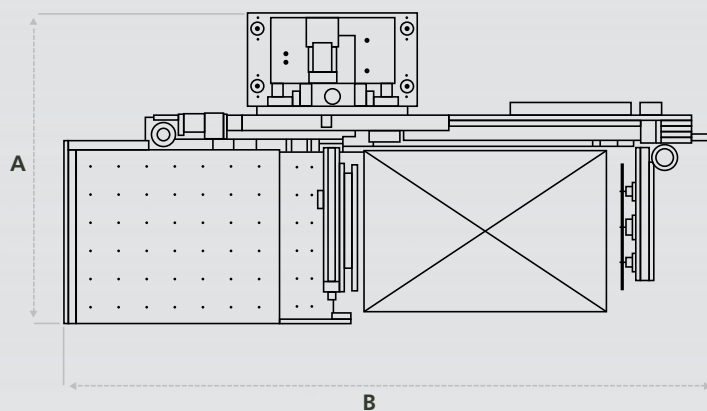

*This machine requires compressed air

For more information about this unloader:
1.800.932.0780 or visit papercutters.com/unloaders

PaperCutters.com
 POWERED BY COLTER & PETERSON