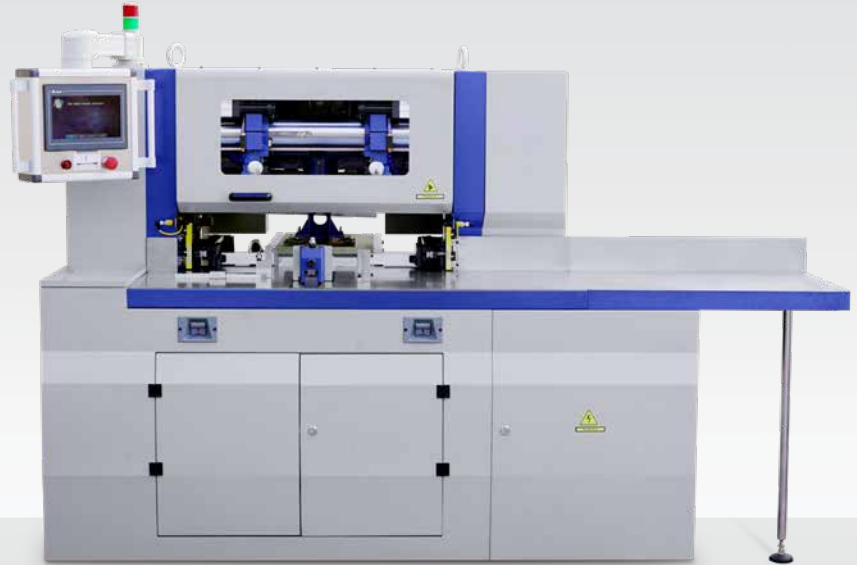

ACCUTRIM[®]**HD1680
Three Knife Trimmer**

FEATURES

- Minor format changes in less than 1 minute
- Complete format change in less than 3 minutes
- PC based machine control
- Easy to use color touch screen for fast programming and troubleshooting
- Versatile 1 or 2 person operation
- 128 MB job storage
- Safety light barrier controls

**Standard Equipment:**

- 1 set of cutting table cassettes (7 pcs)
- Air device for aid in paper waste ejection (house air required)
- Central lubrication system
- Break away head stop (for use with case bound books blocks)
- Out feed delivery conveyor (1 meter length)
- 2 sets of high speed knives in protective boxes
- Spare cutting sticks
- Knife setting gauge
- 2 sets of quick-change knife holders
- 1 set of tools with tool box
- 4 pressing pad holders

Optional Accessories:

- Extra knife sets
- Extra cutting sticks
- Extra knife holders

Method of Operation:

Manual feeding of products to the in feed clamp followed by automatic movement into the main clamping and trimming area. To achieve the best trim quality, the knives are driven mechanically and the clamping is done hydraulically. Trimmed products can be automatically returned (for one operator mode) or delivered onto the out-feed conveyor for maximum through-put.

Automatic cycling (with adjustable timer delay) or push button single cycling can be selected. The programmable PC based controller can store multiple jobs. Servo drives set the in-feed carriage, head stop and side knives automatically through the easy to use color touch screen panel.

Advantages:

- Hydraulic adjustable clamping
- A 5 degree swing angle provides the highest quality of cut and extends knife life, resulting in less overall wear and quieter operation
- The transport pile clamp is adjustable to accommodate a variety of book thicknesses and spine lengths
- The one piece removable cutting table cassettes that prevent the bottom book from marking and allows for faster make-ready and safer cutting stick changes

**PARTS
WARRANTY****LABOR
WARRANTY**

For more information about the HD1680 Three Knife Trimmer:
1.800.932.0780 or visit papercutters.com/HD1680

PaperCutters.com
 POWERED BY COLTER & PETERSON

ACCUTRIM®**HD1680
Three Knife Trimmer**

SPECIFICATIONS

Note: Sizes and Specifications are preliminary and for reference only.

Machine Size:	in	mm
Height with monitor (A)	78	1981
Height (B)	63	1600
Width (C)	83	2108
Depth (D)	92	2337
Table Height (E)	36	914

Size Range:	Spine		Head	
Maximum Trim Size	11.8in	300mm	16.5in	420mm
Minimum Trim Size	3.15in	80mm	3.15in	80mm

Book Thickness:		
Maximum	3.46in	88mm
Minimum (Single book)	.20in	5mm

Capacity:	Cycles Per Minute/Hour up to 28/1680
Power Requirement (Total):	230 volt 3 phase 30 amp
Weight: (Machinery Only):	6160lbs / 2800kg
Air Requirement:	90psi

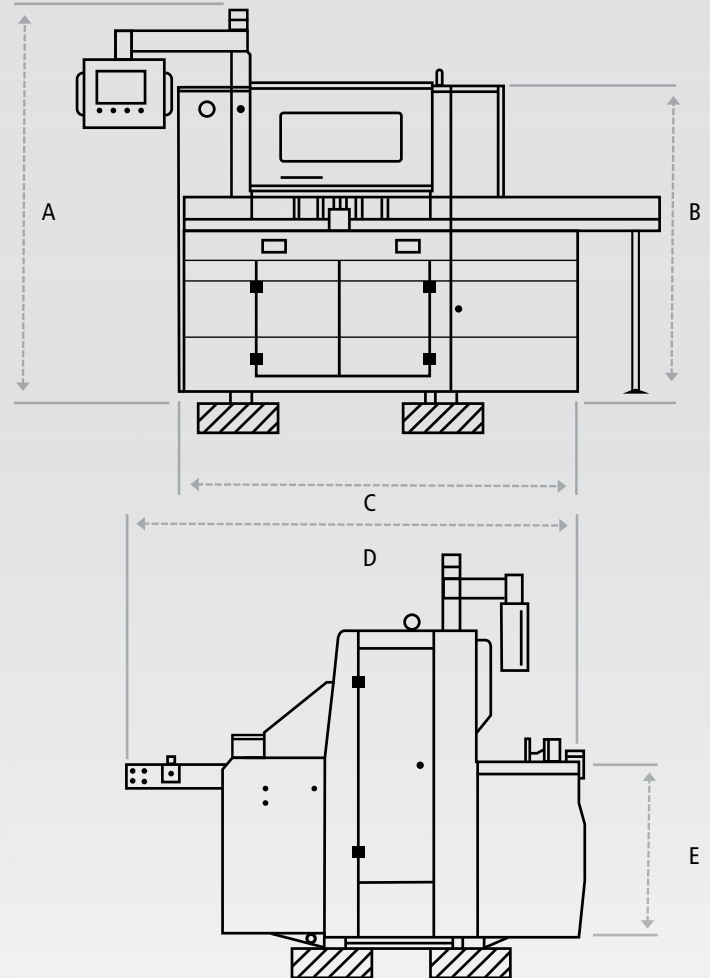

For more information about the HD1680 Three Knife Trimmer:
1.800.932.0780 or visit papercutters.com/HD1680

PaperCutters.com
 POWERED BY COLTER & PETERSON